

SPECIFICATION

1. PHYSICAL DIMENSION(UNIT: m/m):

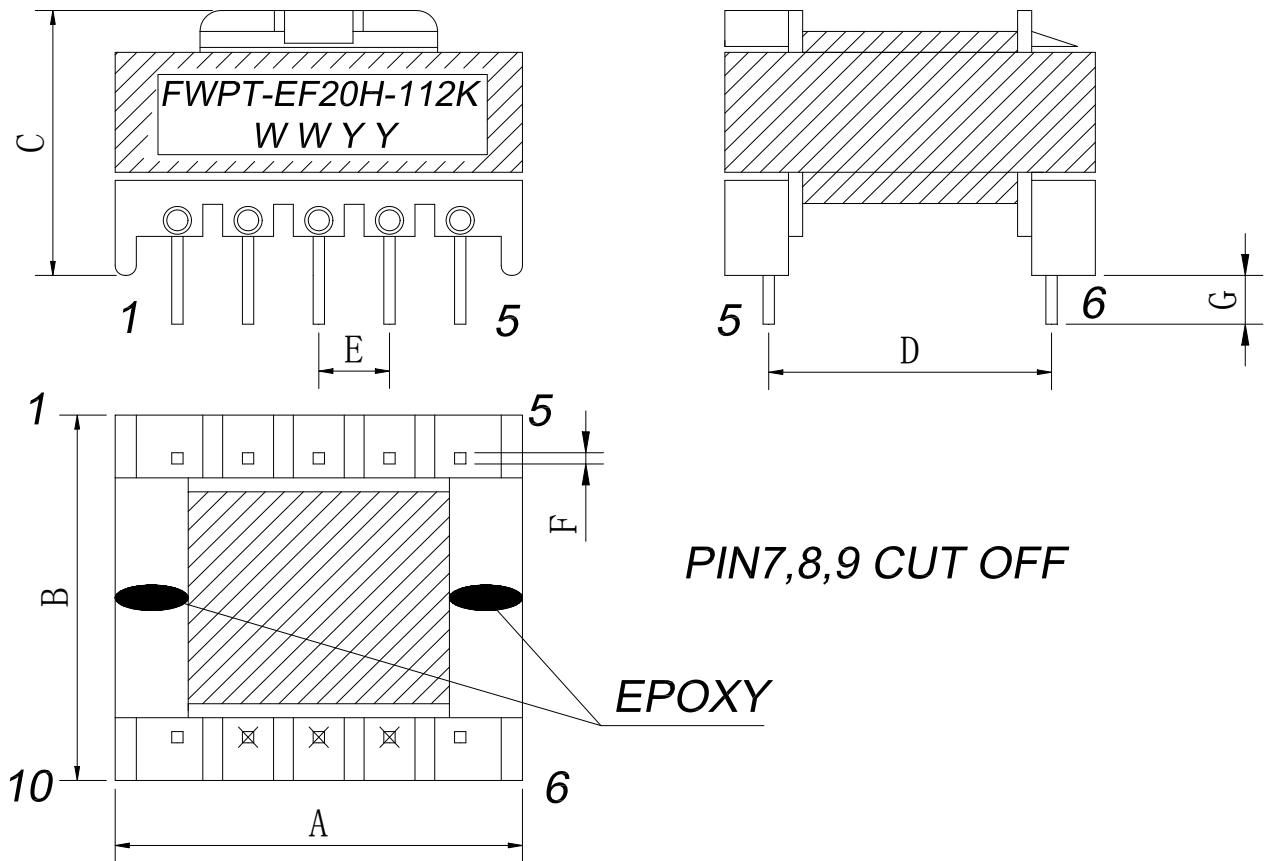

- ※ DIMENSIONS WITHOUT TOLERANCE ARE APPROX
- ※ DIMENSION DOES NOT INCLUDE SOLDER USED ON COILS

LEAD FREE

DIM	A	B	C	D	E	F	G					
	MAX	MAX	MAX	+/-0.5	+/-0.3	REF	+/-0.5					
SPEC	23.0	23.0	18.0	15.0	3.8	0.7	3.5					
						DESCRIPTION		TRANSFORMER				
						Customer P/N						
						FERRIWO P/N		FWPT-EF20H-112K				
SPEC. NO.	PS-1001-003			PREPARED				APPROVED				

SPECIFICATION

2.WINDING TABLE:

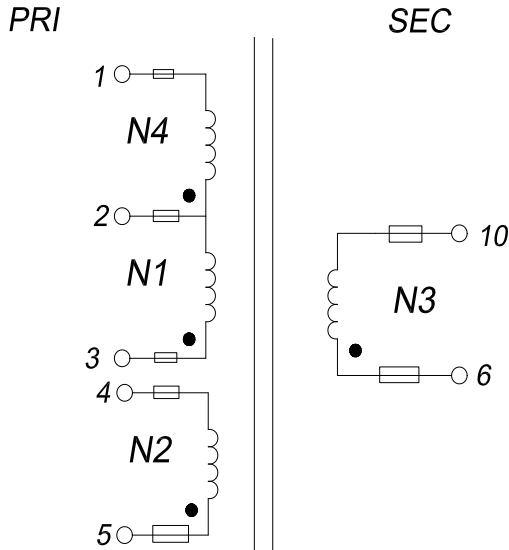

3.WINDING:

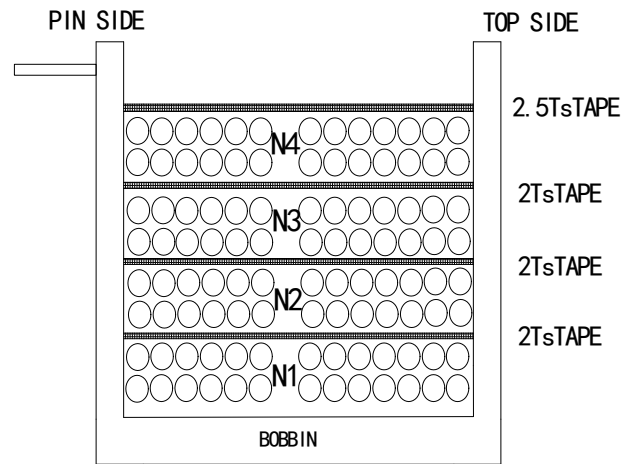

4.WINDING TABLE:

Winding NO.	Margin Tape	PIN	Wire & Wire Copper	Turns	Winding Type	Tape Layer	Tube
N1	0	3~2			Compact	2	F=S=7mm
N2	0	5~4			Compact	2	F=S=7mm
N3	0	6~10			Compact	2	F=S=10mm
N4	0	2~1			Compact	2.5	F=S=10mm

NOTE:

1. Products should be vacuum impregnation

*VARNISH RATIO: 1:1

*VACUUM TIME: 15~20minutes

*BAKED TEMPERATURE : 120°C±10°C, 1~1.5hours

The label as the follow picture:

LEAD FREE

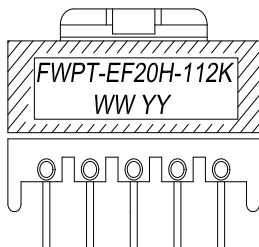

FWPT: FERRIWO POWER TRANSFORMER

EF20H: BOBBIN AND CORE P/N

112K: 1.1mH±10%

WWYY: WEEK YEAR

FERRIWO

DESCRIPTION

TRANSFORMER

Customer P/N

FERRIWO P/N

FWPT-EF20H-112K

SPEC. NO.

PS-1001-003

PREPARED

APPROVED

SPECIFICATION

5. ELECTRONICAL CHARACTERISTIC:

TEST CONDITION : TEMPERATURE AT 25°C

HUMIDITY AT 65 ±5% RH

TEST ITEM	TEST CONDITION	RESULT
INDUCTANCE CH-3250	@1.0KHz,1.0V (3~1)	1.1mH±10%
HI-POT TEST CH-9052	@ 2mA 3SEC (AC)	P<->S 1.5 KV; COIL<->CORE 0.5KV

LEAD FREE

FERRIWO

DESCRIPTION

TRANSFORMER

Customer P/N

FERRIWO P/N

FWPT-EF20H-112K

SPEC. NO.

PS-1001-003

PREPARED

APPROVED

SPECIFICATION

6. MATERIAL LIST :

ITEM		MATERIAL	SUPPLIER OR MANUFACTURER	TEMPRATING
1	CORE	FW95(EE20/20/9)	HAINING FERRIWO ELECTRONICS CO., LTD.	
2	BOBBIN	PA66(FWB2004-J)	HAINING FERRIWO ELECTRONICS CO., LTD.	150℃
3	WIRE	UEW	PACIFIC ELECTRIC WIRE&CABLE(SHENZHEN) CO. LTD UL NO E84081	155℃
4	TAPE	CT280	YAHUA STICKING TAPE CO.,LTD UL NO E165111	130℃
5	TUBE	TEFLON TUBE	GREAT HOLDING INDUSTRIAL CO.,LTD UL NO E156256	200℃
6	VARNISH	R-1038	ZHEJIANG RONGTAI TECHNICAL INDUSTRY CO.,LTD	130℃
7	Flux	TF9100	LINAN GUITONG CHEMICAL TECHNICAL CO.,LTD	
8	Tin	Sn99.3Cu0.7	HAINING ZHUCHANG METAL FOIL CO;LTD	
9	EPOXY	E-500 (black)	SUZHOU EATTO ELECTRONIC MATERIAL CO.,LTD	130℃

LEAD FREE



DESCRIPTION

TRANSFORMER

Customer P/N

FERRIWO P/N

FWPT-EF20H-112K

SPEC. NO.

PS-1001-003

PREPARED

APPROVED